



# **TRANSPAK**

TRANSPAK EQUIPMENT CORP.



MERCURY  
TP-702CQ3-S

**THE WORLD'S VALUE LEADER**  
A WORLD-CLASS STRAPPING MACHINE COMPANY



# MERCURY TP-702CQ3-S

## DESCRIPTION

TP-702CQ3-S is an all-electric high speed corrugated strapper with integrated squaring and backstop functions. It is built based on the quality proven Transpak TP-702 ( corrugated strapper and carries all the innovative features of the TP-702C. Motorized squaring and backstop devices provide precise bundle handling and positioning for forming perfect bundles.

## MAIN FEATURES

### Compact and Robust Strapping Head

- Use the latest brushless DC motor direct drive technology to provide the highest level of accuracy and reliability. All motors are German-made. With compact design and fewer moving parts, it can greatly minimize the maintenance cost.

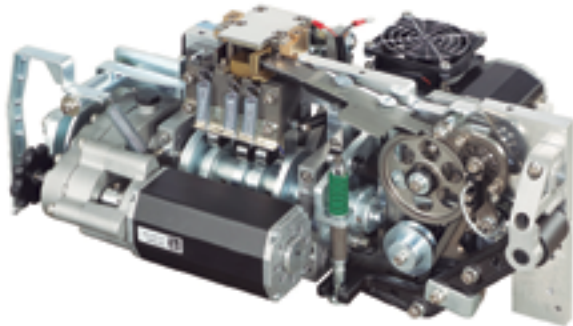

### Good for Small Bundle

- The round belts added on rollers help to move small bundles across strapping position smoothly. It allows a minimum bundle size of width 200 mm (8") x length 250 mm (10").



### 3-Side Squaring Bundle Control

- The electric-driven side squaring and backstop devices optimize the integrity of bundles for strapping. Unique front and rear squaring mechanism with independent control system improves squaring performance over a wider range of bundle sizes.



### Siemens PLC Control and HMI

- Provide easy adjustments, TEACH-IN programming, and troubleshooting guides.



# TP-702CQ3-S



## OPTIONS

- Dual dispenser with auto coil change  
Machine can perform coil change automatically when the strap is running out.
- Light tree alarm with low strap sensor (triple lamp)
- Energy saving transit with auto sleep mode
- Floor rails
- Foot pedal switch
- Bus interface for bundle size data transfer from upstream equipment

## TECHNICAL DATA

<b>Capacity</b>	Up to 24 bundles/minute (single strap) Up to 13 bundles/minute (double straps)
<b>Strap Width</b>	5 mm, 6 mm, or 9 mm
<b>Tension Range</b>	1 - 32 kg
<b>Minimum Bundle Size</b>	250 mm (L) X 200 mm (W) X 50 mm (H)
<b>Maximum Bundle Size</b>	1420 mm (W) X 450 mm (H)
<b>Bundle Weight</b>	max 35 kg
<b>Conveyor Speed</b>	15 - 60 m/minute
<b>Electrical Requirements</b>	220V, 380V, 400V, 415V 50/60Hz 3PH

# TP-702CQ3-S

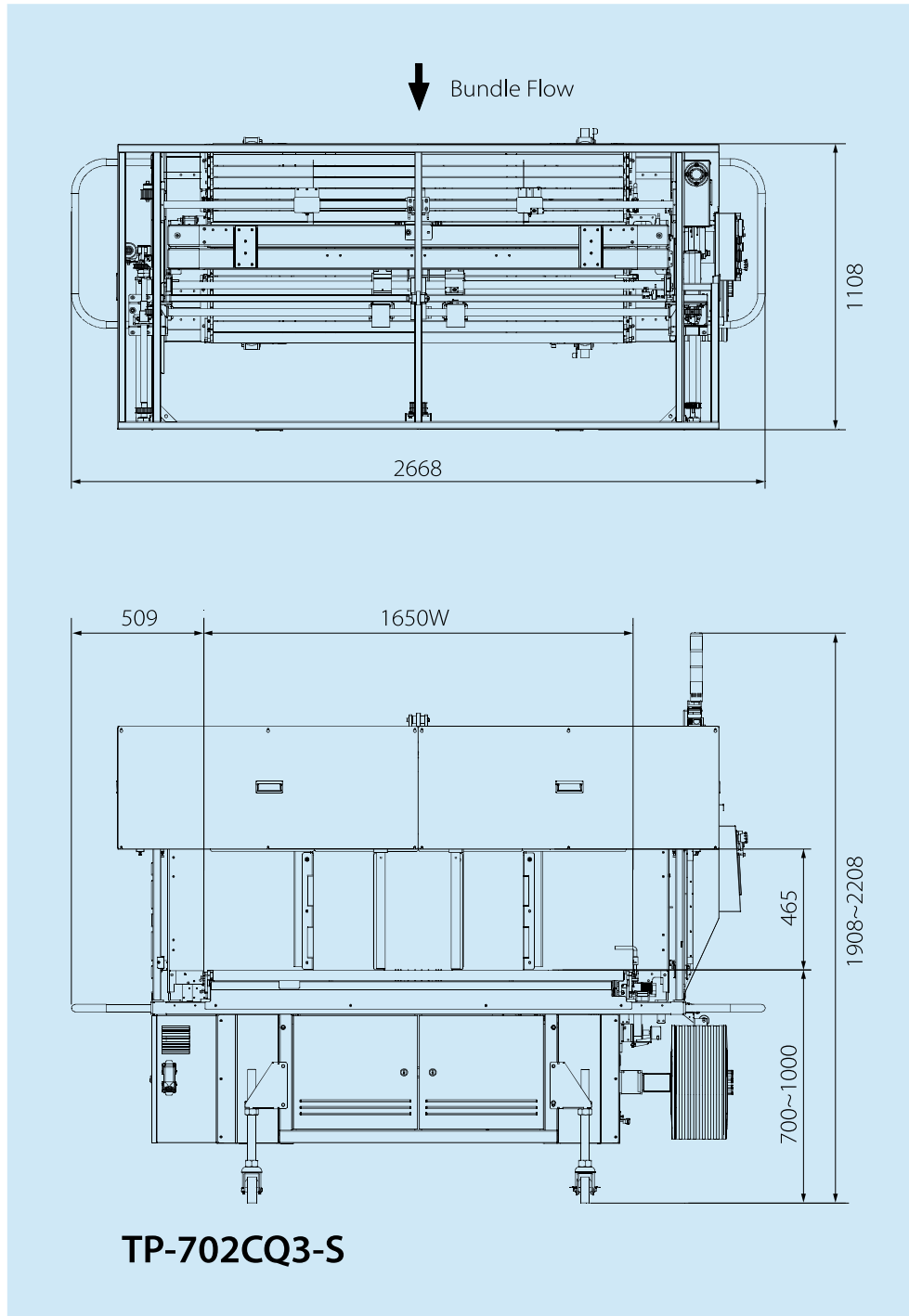

**TRANSPAK**  
TRANSPAK EQUIPMENT CORP.

MADE IN TAIWAN



17901 Von Karman Ave. Suite 600  
Irvine, CA, 92614



[info@corrugatedboxequipment.com](mailto:info@corrugatedboxequipment.com)



[www.corrugatedboxequipment.com](http://www.corrugatedboxequipment.com)



USA 949 242 9516 / 949 556 8744  
MEX 55 7587 7681 / 55 8421 91591