

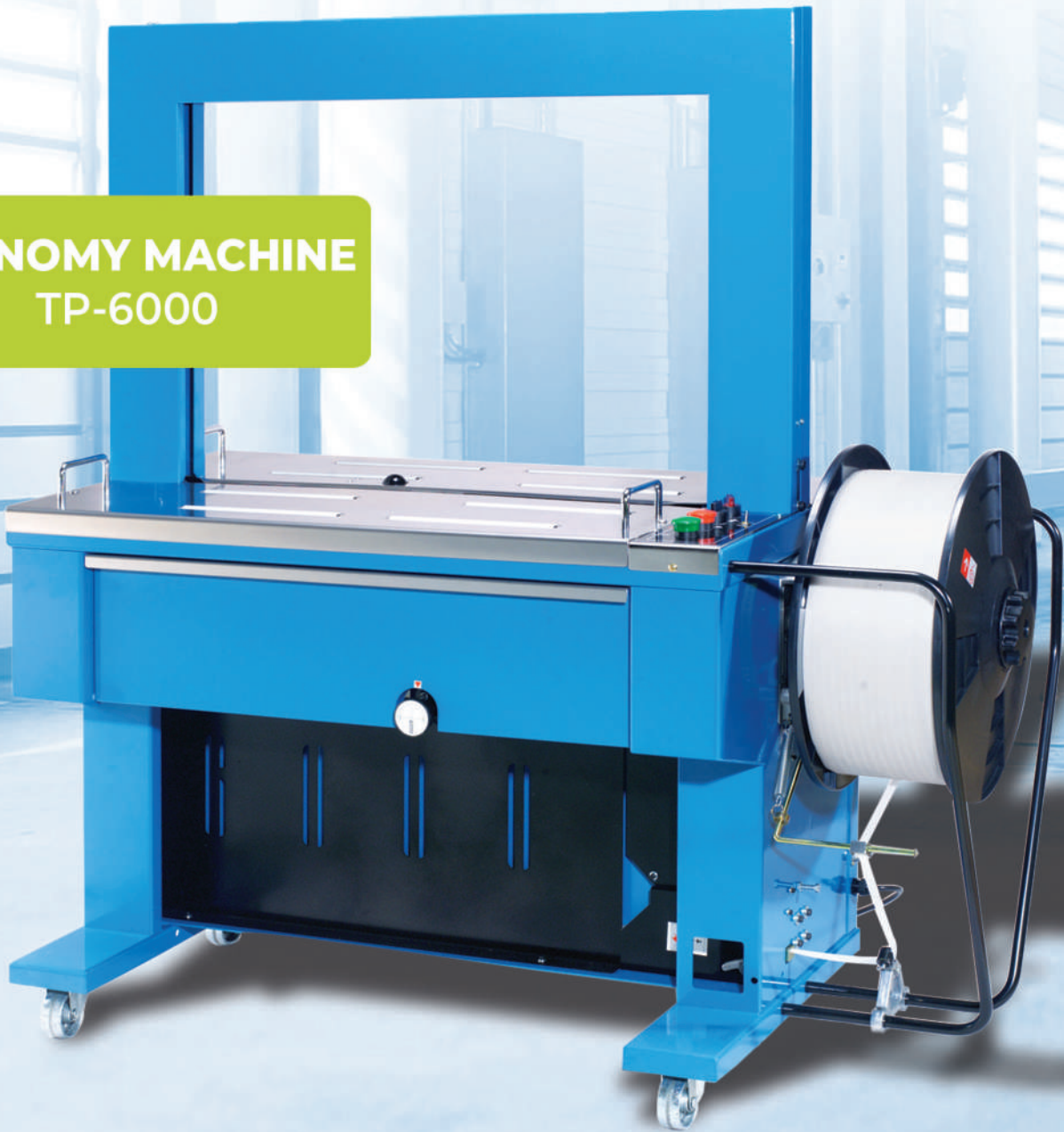

TRANSPAK

TRANSPAK EQUIPMENT CORP.

ECONOMY MACHINE
TP-6000



THE WORLD'S VALUE LEADER
A WORLD-CLASS STRAPPING MACHINE COMPANY



ECONOMY MACHINE TP-6000

DESCRIPTION

Affordable Choice for Every Budget

Use the latest brushless DC motor direct drive technology to provide the highest level of accuracy and reliability. All motors are German-made. Without belts, clutches, and pulleys, its compact design greatly minimizes the numbers of moving parts and maintenance cost.

MAIN FEATURES

Lubrication Free Strapping Head

- Robust mechanism design and high engineering standar ensure excellent durability of the machine. No lubrication is requiered for the strapping head. Therefore, it minimizes the maintenance and saves the cost. Easy maintenance.

External Mechanical Tension Control

- Strap tension can be easily and accurately set with the dial in the front of the machine. Easy operation.

Multiple Methods of Cycle Initiation

- The machine can be operated by several methods, such as foot pedal switch, star switch, or ball activated table switch. Easy operation.

Affordable Choice for Every Budget

- The very competitive price does not come at expense of quality.

OPTIONS

- Short feed sensor
- Smoke exhaust system with carbon filter
- Table without free roller
- PU caster (2 free and 2 with brake)
- Stainless steel frame SUS 304 (TP-6000S)
- CE version (TP-6000CE, TP-6000CES)

TECHNICAL DATA

Capacity	Up to 27 cycles/minute
Strap Width	5 mm, 6 mm, 9 mm, 12 mm or 15.5 mm
Tension Range	10 - 70 kg (CE version: up to 45 kg)
Weight	220 kg
Electrical Requirements	110V, 220V, 230V, 240V 50/60Hz 1PH 220V, 380V, 400V, 415V 50/60Hz 3PH

TP-6000



ARCH SIZES TP-6000

H \ W	650	850	1050	1250	1450	1650
400	✓	✓	✓	✓	✓	✓
600	✓	Ⓢ	✓	✓	✓	✓
800		✓	✓	✓	✓	✓
1000		✓	✓	✓	✓	✓
1200		✓	✓	✓	✓	✓

Ⓢ Standard Size: 850mm (W) x 600mm (H) ✓ Means available arch size

- More arch sizes are on request

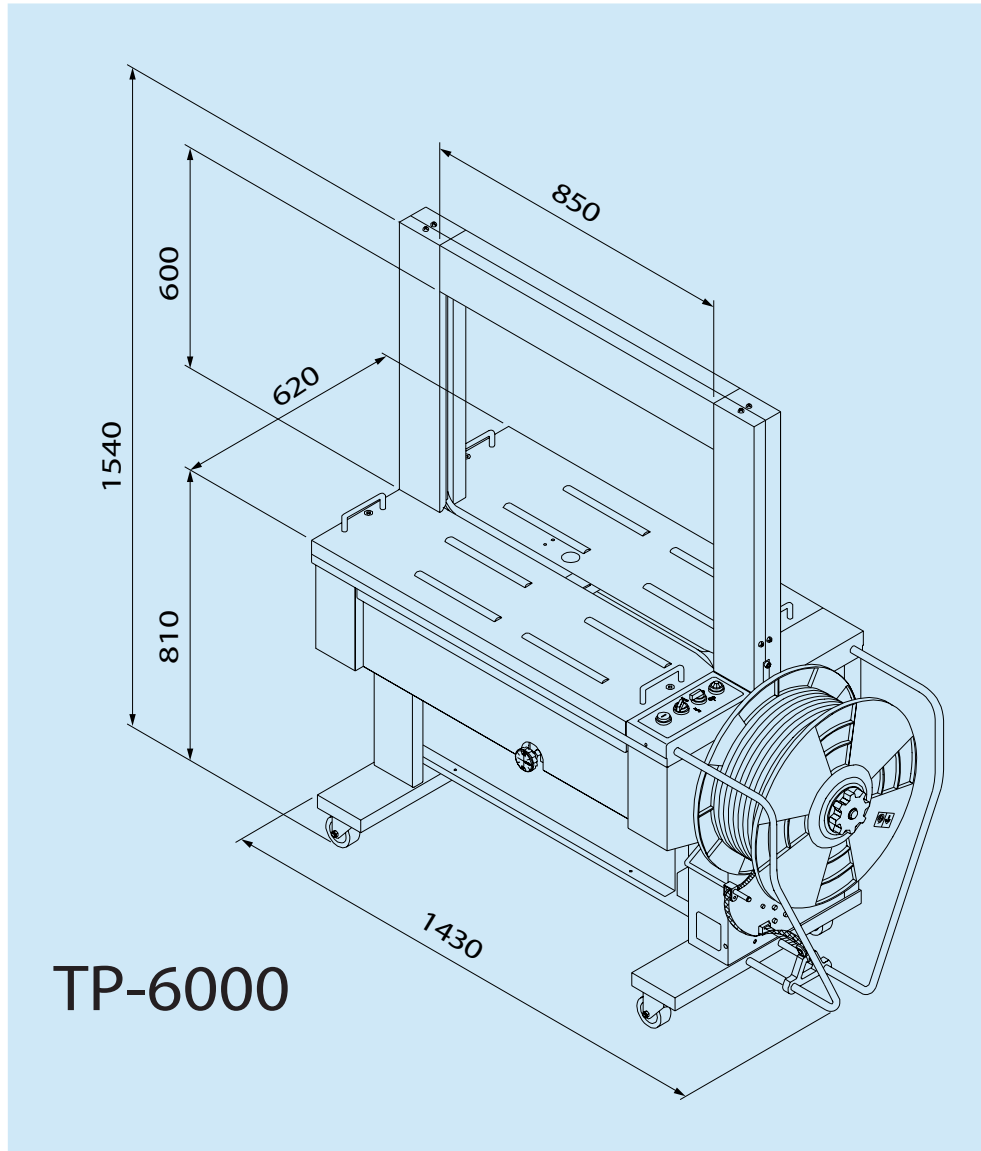

TRANSPAK
TRANSPAK EQUIPMENT CORP.

MADE IN TAIWAN

📍 120 Vantis Drive, Suite 300, Aliso Viejo, CA, 92656

✉ info@corrugatedboxequipment.com

🌐 www.corrugatedboxequipment.com

🇺🇸 USA +1 949 242 9516

🇲🇽 MEX +52 55 69 52 0707