



TRANSPAK

TRANSPAK EQUIPMENT CORP.



**MERCURY
TP-702B**

THE WORLD'S VALUE LEADER
A WORLD-CLASS STRAPPING MACHINE COMPANY



MERCURY TP-702B

DESCRIPTION

TP-702B are fully automatic strapping machines for fast production and packaging lines. It is suitable for 5 mm, 6 mm, 9 mm, or 12 mm PP strapping.

MAIN FEATURES

Robust and Compact Strapping Head

- Use the latest brushless DC motor direct drive technology to provide the highest level of accuracy and reliability. All motors are German-made. Without belts, clutches, and pulleys, its compact design greatly minimizes the numbers of moving parts and maintenance cost.



Free Access to Strap Guides

- Hinged top plate makes easy access to the strapping head for quick maintenance. Unblocking the guides enables free and quick access to strap guides without using any tools. The most maintenance friendly design.



Waist-High Auto Strap Feeding

- Friendly design to feed the strap automatically from the upper side of the coil without the need to access to the bottom of the machine.



Electronic Tension Control

- The operating control panel with LCD display is located on upper side of the machine for easy access. Strap tension can be adjusted accurately by a simple turn of the dial.

OPTIONS

- Siemens PLC
- Light tower with low strap sensor
- Energy saving transit with auto sleep mode
- Strapping in the center of the bundle
- Strapping controlled with 2 photo eyes
- Extension belt-driven table of 200 mm on upstream or downstream sides
- Dual channel E-Stop
- Lower adjustable table height from 750 mm to 900 mm

TP-702B

ARCH SIZES TP-702B

H \ W	550	650	850	1050
500	✓	(S)		
600			✓	
800			✓	✓
1000			✓	

(S) Standard Size: 650mm (W) x 500mm (H)

✓ Means available arch size



TECHNICAL DATA

Capacity	Up to 40 packages/minute (Cycle speed up to 65 cycles/minute)
Strap Width	5 mm, 6 mm, 9 mm, or 12 mm
Tension Range	1 - 32 kg (for 5 mm, 6 mm, 9 mm) 1 - 45 kg (for 12 mm) *Higher tension is on request
Weight	225 kg
Electrical Requirements	110V, 220V, 230V, 240V 50/60Hz 1PH 220V, 380V, 400V, 415V 50/60Hz 3PH

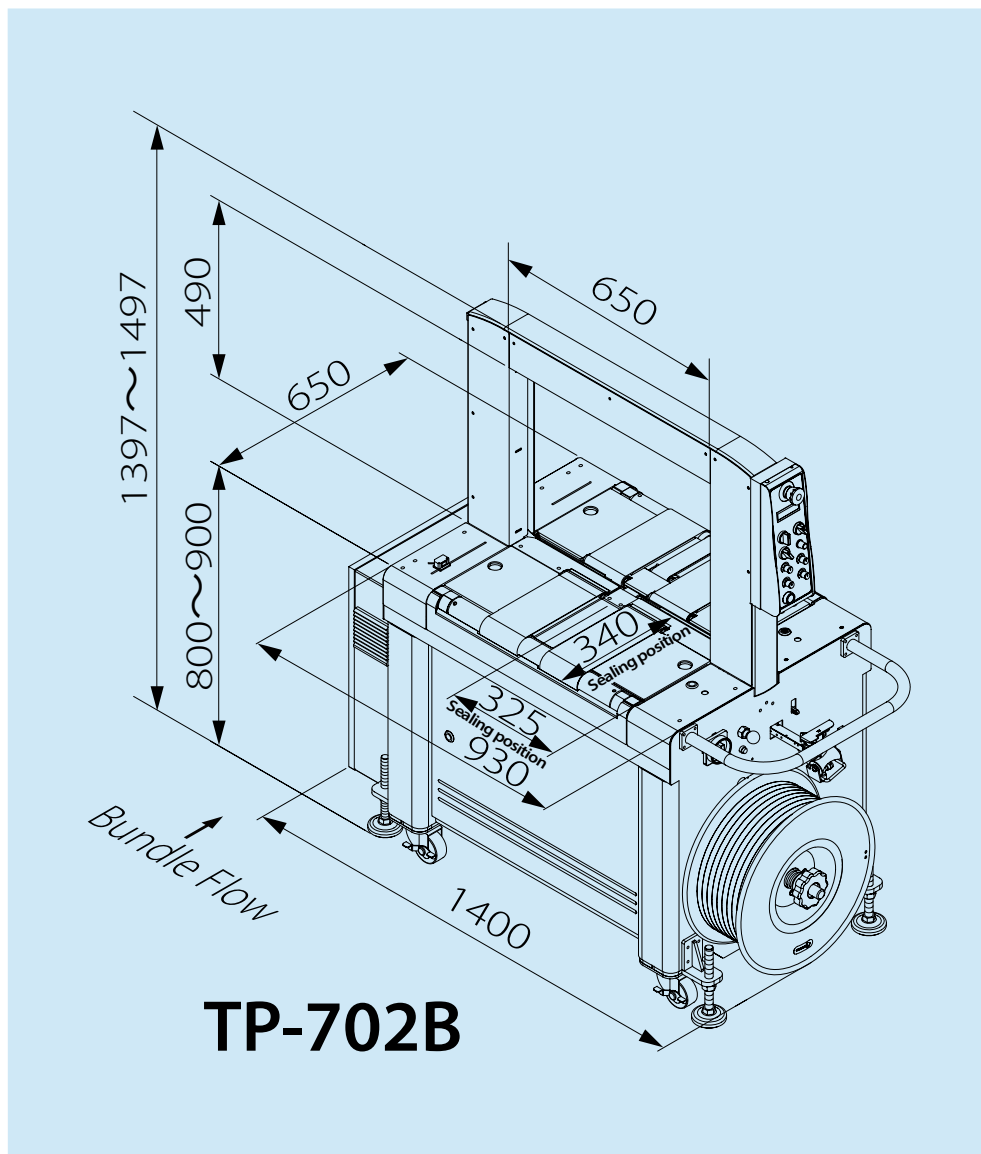

TRANSPAK
TRANSPAK EQUIPMENT CORP.

MADE IN TAIWAN



17901 Von Karman Ave. Suite 600
Irvine, CA, 92614



info@corrugatedboxequipment.com



www.corrugatedboxequipment.com



USA 949 242 9516 / 949 556 8744
MEX 55 7587 7681 / 55 8421 91591